

DUEGI srl
Via Delle Crede 10G
33170 - Pordenone (PN)
t: +390434604119
info@duegilight.com
P. IVA 01669240937
www.duegilight.com

DUEGI.CA.002.2024



**SOLUZIONI ILLUMINOTECNICHE
BROCHURE**



Lampade cartongesso

Ghost 2

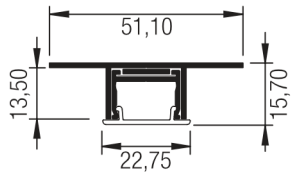
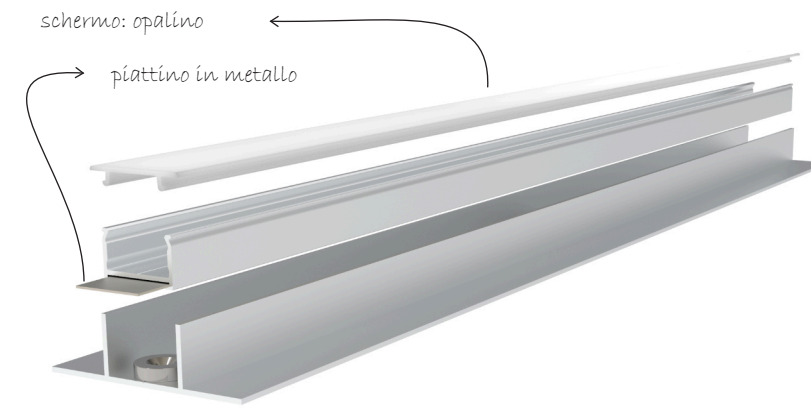

scale 1:2

La lampada Ghost 2 è stata progettata per rendere l'installazione sul cartongesso il più semplice possibile. Le clip sono state sostituite da delle calamite che attirano il profilo alla controcassa garantendo facilità e velocità del montaggio.

Applicazioni



COMBINAZIONI DISPONIBILI

POTENZA	VOLT	LUMEN	CCT	INTERRUTTORI
14.4 watt/mt	24 V	1944/2016/2160 lm/mt	2700/3000/4000 K	<input type="checkbox"/> IP 20 <input type="checkbox"/> CRI >80 <input type="checkbox"/> CRI >90 <input type="checkbox"/> CE
19.2 watt/mt	24 V	2500/2785 lm/mt	3000/4000 K	
RGB+WW	24 V			
12 watt/mt	48 V	1400/1520/1630 lm/mt	2700/3000/4000 K	
20 watt/mt	48 V	2050/2160/2250 lm/mt	2700/3000/4000 K	

Montaggio



Fissare la controcassa Ghost 2 al montate del cartongesso



Una volta fissata la controcassa si procede con il fissaggio del pannello di cartongesso. L'installazione dovrà essere eseguita da personale qualificato

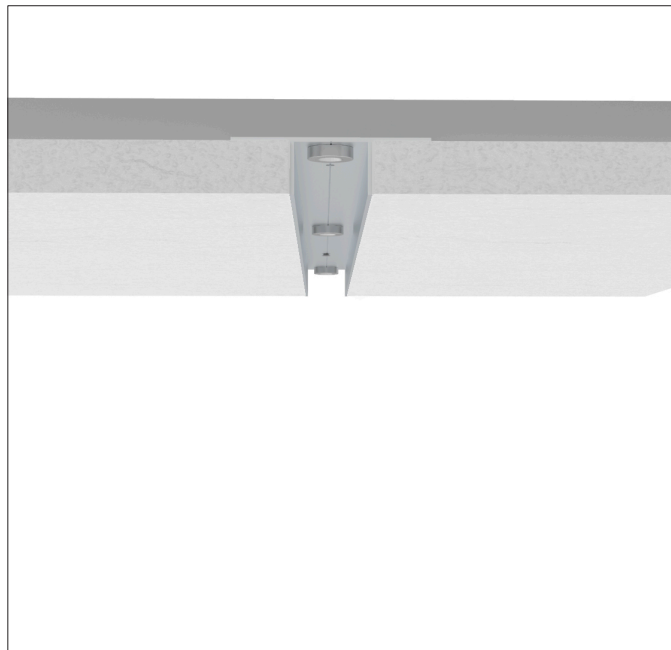

Fissare le calamite



Avendo inserito in precedenza un piattino in ferro, la calamita attira il profilo Ghost 2 e ciò garantisce il sostegno della lampada

Applicazioni

